

# 产品尺寸图 (DIMENSION)

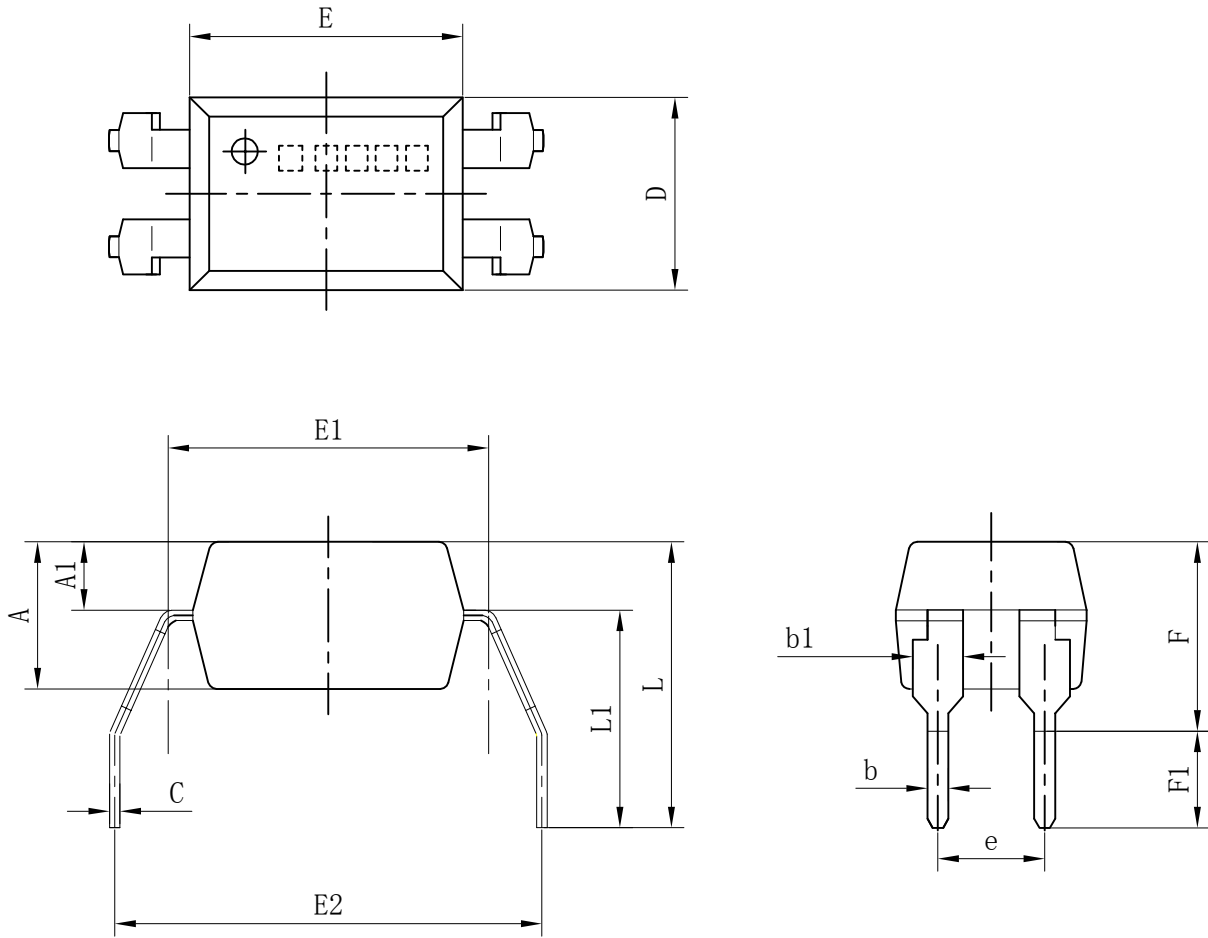
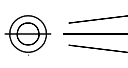

symbol	Dimensions In Millimeters			Dimensions In Inches		
	Min	Nom	Max	Min	Nom	Max
b1	1.25	1.30	1.35	0.049	0.051	0.053
e	—	2.54	—	—	0.100	—
A	3.20	3.50	3.80	0.126	0.138	0.150
A1	1.42	1.62	1.82	0.056	0.064	0.072
C	0.20	0.25	0.30	0.008	0.010	0.012
E1	TYP. 7.62			TYP. 0.300		
E2	9.66	10.16	10.66	0.379	0.400	0.419
L	5.80	6.80	7.80	0.228	0.268	0.308
L1	4.68	5.18	5.68	0.184	0.204	0.224
E	6.30	6.50	6.70	0.248	0.256	0.264
D	4.40	4.60	4.80	0.173	0.181	0.189
b	0.47	0.50	0.53	0.018	0.019	0.020
F	4.20	4.50	4.80	0.165	0.177	0.189
F1	1.80	2.30	2.80	0.070	0.090	0.110

# FSMC

图名 NAME	DIP-4M/DIP-4MC		图号 DWG. NO.	DD0049	SH 1 OF 1
材质 MATERIAL	SPCE/LY65		REV.	D	
单位 UNITS	mm [INCH]	核准 APPROVE	审核 CHECKED	制图 DRAWN	 第三角法
日期 DATE	2020-07-07				
比例 SCALE	N. T. S.				

11-3001  
01-01